

# POWERFLEX®

PART NUMBER

**PFR85-262G**

DESCRIPTION

**Rear Trailing Arm Bush Adjustable**

## INSTALLATION GUIDE

### Contents (parts per pack):

2 x Polyurethane Bushes      1 x PTFE/Silicone Grease  
2 x Stainless Steel Sleeves    2 x Nylon Washers

Please read the complete fitting instructions and check package components before fitment. These fitting instructions are to be used as a guide and in conjunction with workshop manual.

It is recommended that:

- all work to be carried out by a licensed technician;
- all safety precautions adhered to;
- wheel alignment to be checked and adjusted as required after any suspension work.
- All fasteners must be tensioned to manufacturer's torque settings.

### Fitting Instructions:

1. Remove the original rubber bush from the rear trailing arm.
2. Clean any dirt and corrosion from the bore of the rear trailing arm and file off any sharp edges.
3. Fully press the bushes into each end of both sides of the arm. Ensure they sit flush to the surface of the arm.
4. Apply some of the supplied grease to the bore of the polyurethane parts and insert the stainless steel sleeve into the bore until it sits flush within the bush. The sleeve should be pushed in so that the hexagonal surface is facing outwards from the arm.
5. Using the supplied spanner, adjust the position of the bore to desired position. Refer to Figure 1 and 2 to determine the effects of each position. Ensure angles are symmetrical for both sides of the car.
6. Refit hardware tension all hardware to manufacturers recommended torque settings. Test drive and re-adjust if necessary.



Note: Wheel angles are exaggerated for illustrative purposes.

Figure 1 - Maximum negative camber illustrated.

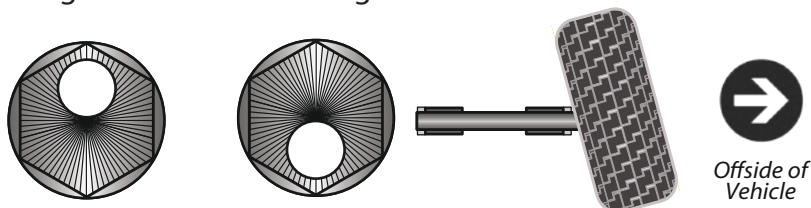

Figure 2 - Maximum positive camber illustrated.

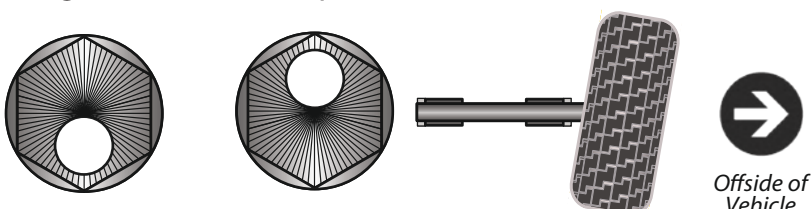

Figure 3 - Maximum positive toe angle.

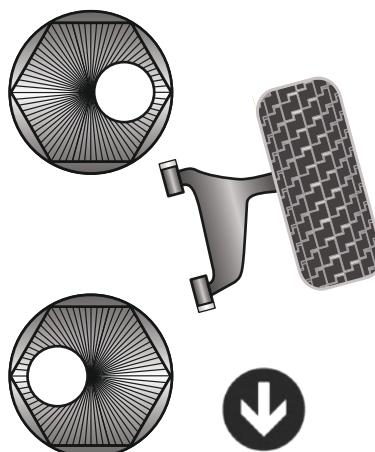

Figure 4 - Maximum negative toe angle.

